

Standard Package

www.fiberfox.co.kr

Mini 22A

4 Motors Active Alignment Splicer



- 1 MINI 22A Splicer
- 2 Cleaver Softcase
- 3 MINI 50G Cleaver
- 4 Power Cord
- 5 USB Cable
- 6 AC Adapter
- 7 Car Cigar Cable
- 8 Cooling Tray
- 9 Spare Electrode
- 10 SOC Heater Block
- 11 SOC Holder
- 12 1 Battery Pack
- 13 Shoulder Strap
- 14 User Manual CD
- 15 Hand Carrying Case

Specifications

Splicing Method	Active Alignment DAA(Digitalized Active Alignment)
Average Loss	SM(0.02dB) / MM(0.01dB) / DS(0.05dB) / NZDS(0.05dB) / G.657(0.02dB)
Return Loss	>>60dB
Splice Time	12s average SM / SM 7s Quick mode
Electrode Lifespan	>3,500 arcs
Applicable Fiber	SM(ITU-T G.652, MM(ITU-T G.651), DS(ITU-T G.653), NZDS(ITU-T G.655), IT-G657A, IT-G657B 0.25mm, 0.9mm, 2.0mm, 2.4mm, 3.0mm, FLAT(indoor cable)
Cleaved Length	Coating Diameter < 0.25mm = 5-16mm, Coating Diameter > 0.25mm = 8-16mm minimum
Coating Diameter	100-1000um
Cladding Diameter	80-150um
Heating Programs	Factory installed mode : 3, User installable mode : 23
Heating Time	Typical 18s
Protection Sleeve	40mm, 60mm, SOC-3.0, SOC-0.9
Data Output	Micro HDMI-USB master device
Splice Programs	8 user modes, User installable mode : 70+
Splice Memory	Up to 2000 records
Battery	Typical 200 Cycles (Splice & Heat)
Power Supply	AC 100-240V input or DC 9-14V
Monitor	Color 4.3" LCD monitor, with Touch Screen (Tempered Glass)
Cameras	2 CCD camera system
Magnification	XY : 150 times , X/Y : 300 times
Fiber Display	X/Y or XY, single X.Y
Weight	1.31Kg (without battery)
Size	122mm X 124mm X 138 mm
Wind Protection	The max wind speed 15m/s
Operating Environment	Elevation 0-5000 meters, -15~60°C, 0-95% relative humidity
Storage Condition	Temperature -40 to 80°C, 0-95% relative humidity, battery -20-30°C
Pull Test	1.96-2.25N (standard)
Attenuation splicing	Range : 0.1dB ~ 20dB (0.1dB step)



4 Motors Active Alignment Splicer

1.31
kg

200
cycles

7
sec

0.02
dB

Characteristic

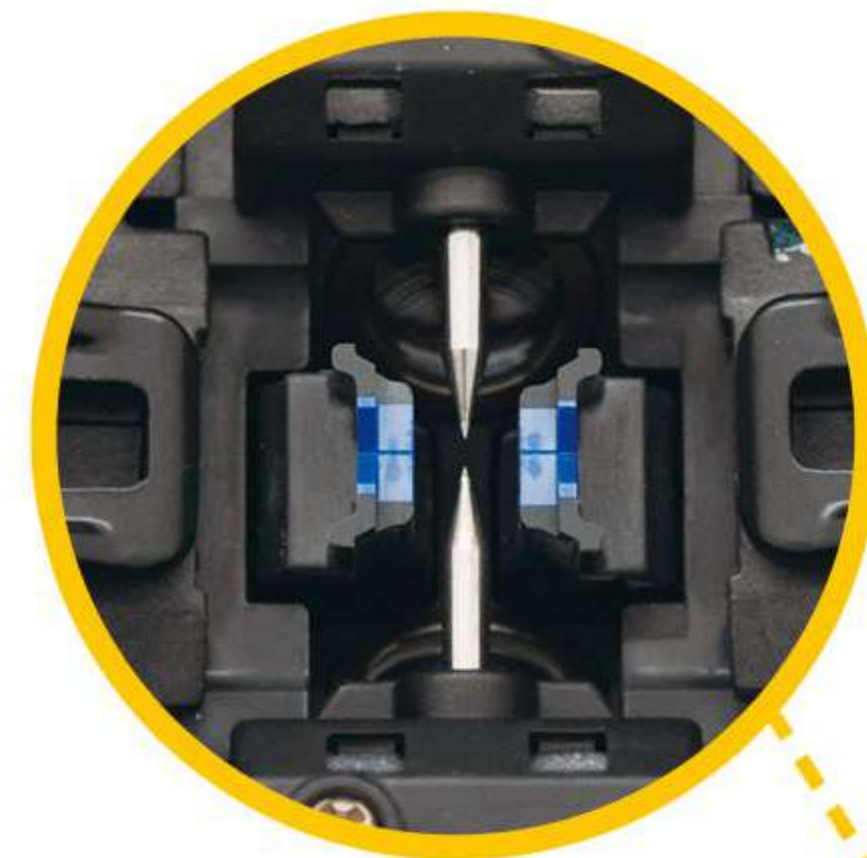

Applicable Cleaved Length
- Up to 5mm



Heating Time
- 18 sec <60mm sleeve>



Universal Holder
- 250
- 900
- 2~3
- Indoor

Mini 22A

1.31kg
(Without Battery)

122 x 124 x 138 mm

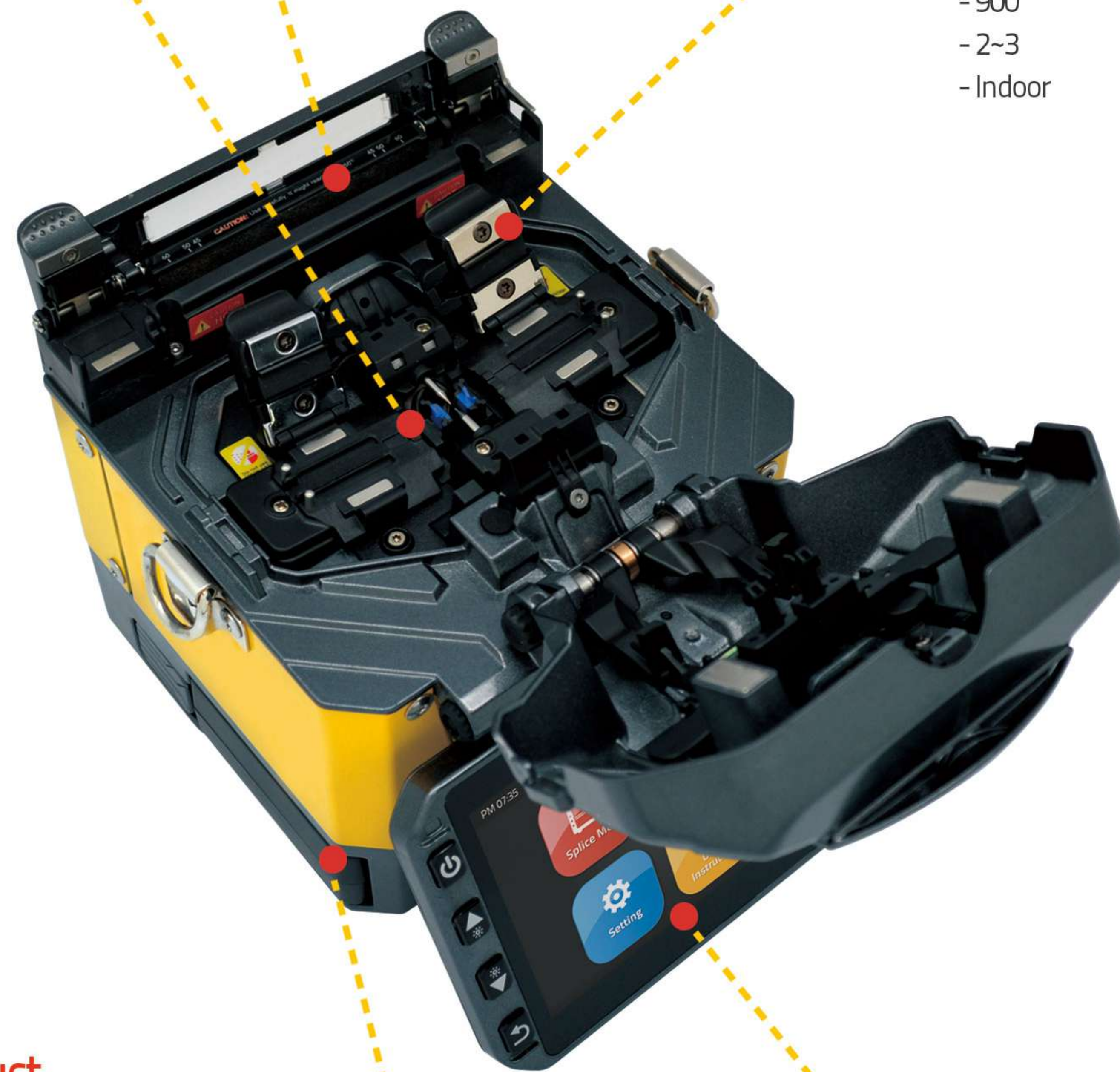

Optional product



Work Table Bag



One Battery is Included in Standard Package
- 200 cycles (splicing & heating)



Full Touch Screen
- GUI Interface
- Tempered Glass

01 Performance

Performance

Perfect performance under any environmental conditions

- Temperature: -15~60°C
- relative humidity: 0~95%
- Elevation: 0~5000meter
- The max wind speed: 15m/s

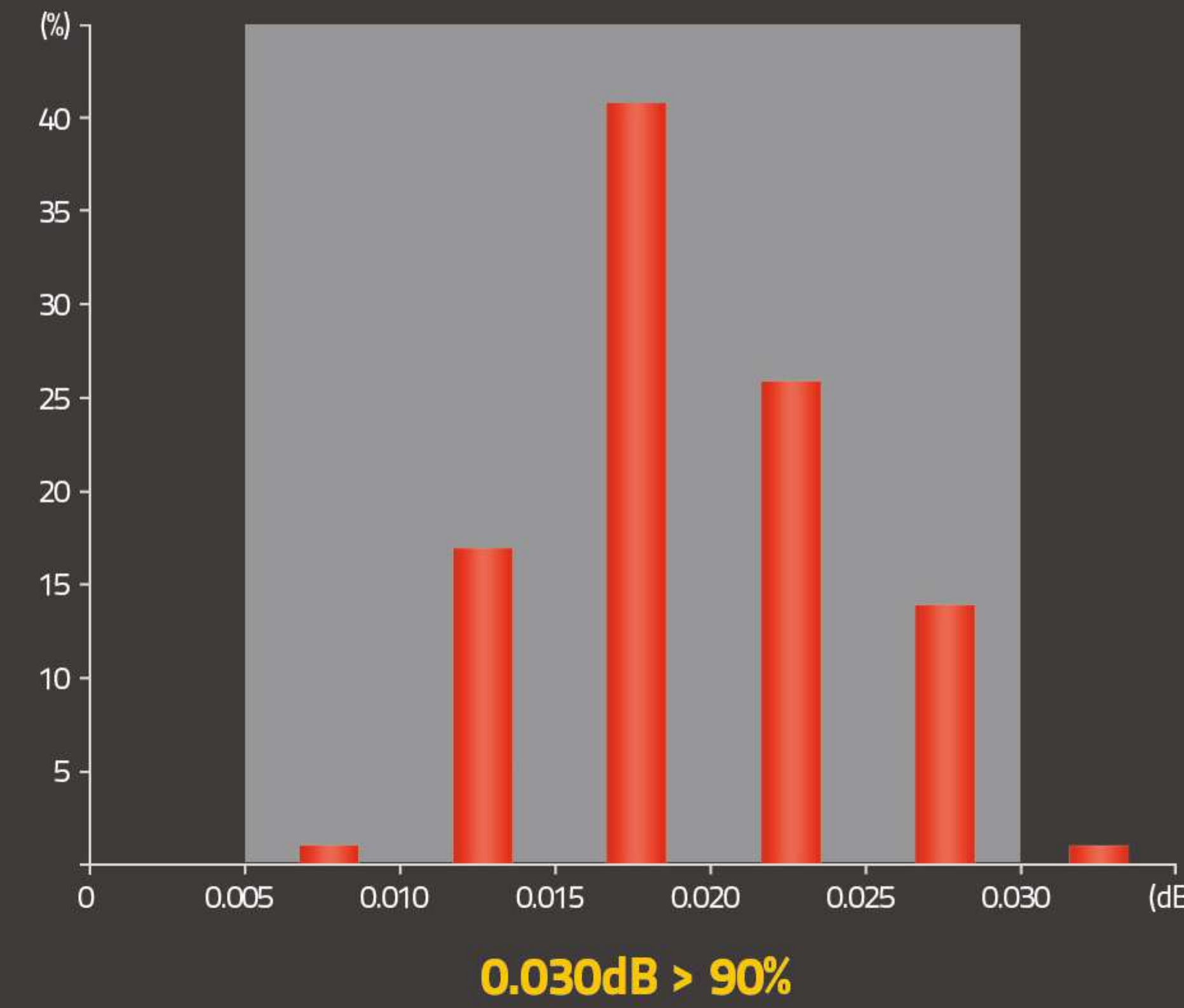

02

SOC Compatible



03

Durability



1meter

Anti-shock

04

FTTH Solution

Dustproof

Waterproof

